

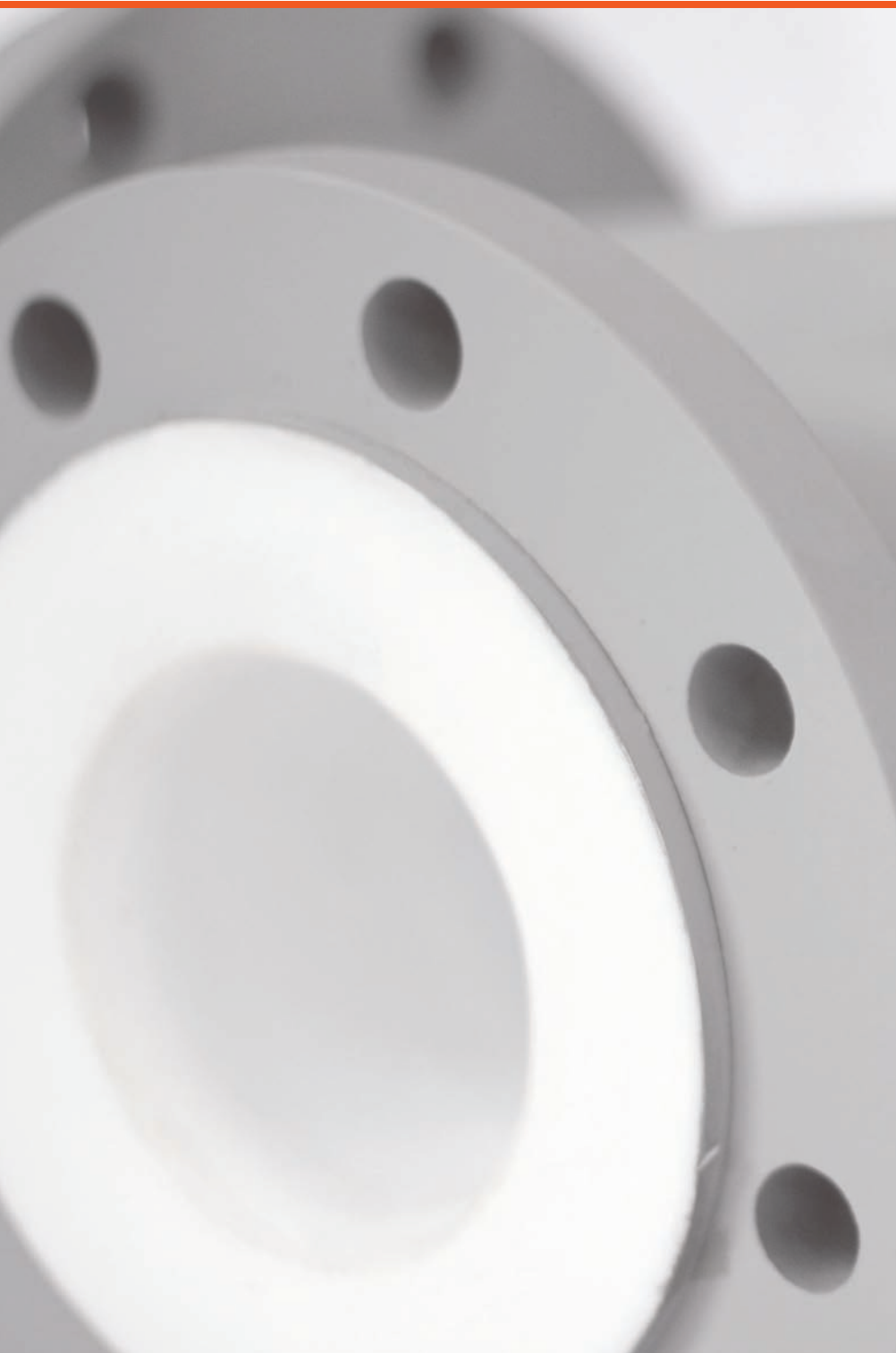

ARMYLOR® 2
PTFE / PFA
LINED PIPES
AND FITTINGS
DIN 2848



CONTENT

EXPERTISE **p.1**

MERSEN ANTICORROSION EQUIPMENT **p.2**

PTFE / PFA POLYMERS **p.3**

PTFE / PFA LINING **p.4**

STEEL PARTS **p.7**

LINED COMPONENTS **p.9**

QUALITY CONTROL **p.10**

INSTALLATION PROCEDURES **p.11**

CODING SYSTEM AND REFERENCES **p.13**

PRODUCTS **p.14**

EXPERTISE

Mersen has an engineering team dedicated to customer services.

Our experts help study the best technical & economical solutions for your projects. This team can also assist our customers to produce isometric drawings in order to create a list of fittings / components.

The specification or data herein contained are only given for indication, without any undertakings whatsoever. Their publication does not suggest the matter is free of any rights whatsoever. Furthermore, due to constant evolution of techniques and norms, we reserve the right to modify, at any time, the characteristics and specifications contained in this document. MERSEN refuses all and any responsibility concerning their use whatever the purpose or application. Any copy, reproduction or information herein contained, in whole or in part, made without MERSEN written consent, is forbidden according to the laws of France and particularly the law nr. 92-597 of July 1st 1992 relating to the copyright.



MERSEN ANTICORROSION EQUIPMENT

The Mersen AntiCorrosion Equipment activity is internationally recognized for its expertise in the design and manufacture of process equipment, manufactured from corrosion resistant materials (graphite, silicon carbide, tantalum, zirconium, PTFE).

Mersen also has an in-depth knowledge of the process technologies requiring our AntiCorrosion Equipment and can provide offers from the basic equipment only, up to skid-mounted turn-key process packages.

Since 1964, Mersen has been offering an exhaustive range of PTFE / PFA lined pipe and fittings especially designed for conveying corrosive fluids in both the chemical and pharmaceutical industries.

THE PRODUCT RANGE CONSISTS OF :

- PTFE / PFA lined pipe and fittings
- PTFE bellows (expansion joints) and compensators

	HEAT EXCHANGERS				PRESSURE VESSELS & COLUMNS
GRAPHITE	 POLYBLOC	 POLYTUBE	 CUBIC	 ANNULAR GROOVE	 COLUMN
SILICON CARBIDE	 BLOCK	 SHELL & TUBE	 PLATE & FRAME	 PTFE	
TANTALUM	 SHELL & TUBE	 COIL	 BAYONET	 COLUMN	
ZIRCONIUM, TITANIUM AND NICKEL ALLOYS	 ZIRCONIUM	 TITANIUM	 NICKEL ALLOYS	 PRESSURE VESSEL	
PTFE PIPING, COMPENSATORS, BURSTING DISCS, TANTALUM SMALL PARTS					
	 PTFE LINED PIPING	 PIPE BELLOW	 GRAPHITE BURSTING DISC	 TANTALUM SMALL PARTS	

PROCESS TECHNOLOGIES



HCl, HBr AND H₂SO₄ SKID-MOUNTED UNITS

SERVICE CENTERS



REPAIR, SPARE-PARTS, PREVENTIVE MAINTENANCE...

PTFE / PFA POLYMERS

DEFINITION

Available lining materials for our product range are as follows :

- ▶ Virgin or anti-static* PTFE (Polytetrafluoroethylene), in accordance with ASTM D4894 & 4895 standards.
- ▶ Virgin or anti-static* PFA (perfluoroalkoxy), according to ASTM D3307** standard.

* Conductive black PTFE or PFA

** Also on request according to DIN 53455 standard

GENERAL CHARACTERISTICS

Values indicated in the following table are given for virgin PTFE and PFA.

These characteristics can vary depending on the material grades from the various suppliers, the transformation process and the batch.

PROPERTIES	UNITS	PTFE	PFA
Physical			
Density	g/cm ³	2.13 - 2.19	2.12 - 2.17
Water absorption : 24h thickness 3,2 mm	%	<0.01	0.03
Mechanical			
Tensile strength	MPa	20 - 40	27 - 32
Elongation at break	%	250 - 500	300 - 500
Modulus of elasticity under elongation	MPa	350 - 750	650 - 700
Modulus of elasticity under flexural stress	MPa	440 - 670	590 - 700
Hardness shore D mandhod		50 - 72	60 - 65
Thermal			
Flame propagation		hard	hard
Melting point	°C	327 and 342	300 to 310
Other transitions	°C	-90*,+123,* +27**	-80*, 90*
Maximum service temperature	°C	-200/+260	-150/+260
Temp. of deflection under load (1.82 MPa)	°C	50 - 60	50
Linear elongation coefficient	10 ⁵ / °C	10 - 25	12
Thermal conductivity	W / m.K	0.24	0.25
Electrical			
Dielectric constant from 60 Hz to 107 Hz		2.2	2.1
Volume resistivity	Ω.cm	10 ¹⁸	10 ¹⁸
Surface resistivity	Ω	10 ¹⁷	10 ¹⁷
Spark test (thick.mm)	kV / mm.K	36(1)	80(2.3)

*amorphous phase, **crystal phase

RECEIVING INSPECTIONS

Material certificates from the PTFE / PFA powder manufacturers are checked and identified with batch numbers. On request, FDA certificates (Food and Drug Administration) can be supplied.

PTFE / PFA LINING

Mersen proposes 2 ranges of Armylor® 2:

- Armylor®2 G to operate under pressure
- Armylor®2 V to operate under pressure and vacuum

PTFE / PFA NOMINAL THICKNESS

DN	15	20	25	32	40	50	65	80	100	125	150	200	250	300	350	400	500	600
G															7,5	7,5	7,5	7,5
V	3	3	3	3	4	4	4	4	4,5	6	7	7,5	7,5	7,5				

The minimal thickness of the PTFE tube is equal to the nominal minus 10% - The thickness of the flare cannot be lower than the nominal thickness, minus 20%.

TESTS ON PTFE / PFA

Physical and mechanical tests

For each manufacturing batch, Mersen checks the mechanical & physical properties.

Values for elongation at break point and tensile strength, together with regularity of the graph confirms that the liner sintering has re-established the isotropy of PTFE, which guarantees a low level of permeability.

Parallel direction

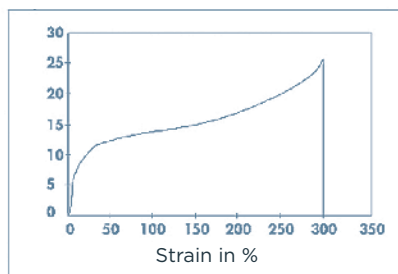

Perpendicular direction

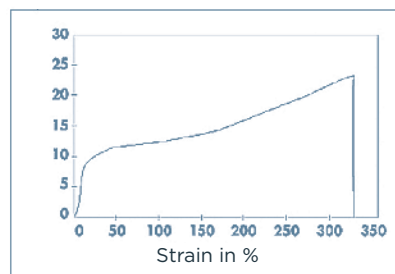

PTFE / PFA LINING

Optimal density ensures a balance between a low permeability level and a good distortion during temperature cycles.

	MECHANICAL PROPERTIES		PHYSICAL PROPERTIES	
	Tensile strength	Elongation at break	Density	
PTFE Extruded Virgin Test according to standard	+ 21 N/mm ²² (// Direction) + 17 N/mm ² (⊥ Direction) ASTM D4895	+ 250% (// Direction) + 200% (⊥ Direction) ASTM D4895	2.14 - 2.19 ASTM D792	2.13 - 2.19 DIN 53749
Antistatic Test according to standard	+ 21 N/mm ² (// Direction) + 17 N/mm ² (⊥ Direction) ASTM D4895	+ 250% (// Direction) + 200% (⊥ Direction) ASTM D4895	2.13 - 2.19 ASTM D792	2.12 - 2.18 DIN 53749
PFA Virgin Test according to standard	+ 26 N/mm ² ASTM D3307	+ 300% ASTM D3307	2.12 - 2.17 ASTM D792	2.12 - 2.17 DIN 53749
Antistatic Test according to standard	+ 26 N/mm ² ASTM D3307	+ 300% ASTM D3307	2.11 - 2.17 ASTM D792	2.11 - 2.16 DIN 53749

The results comply with the ASTM F1545 standard

ANTISTATIC PTFE / PFA ELECTRICAL PROPERTIES

Transverse resistivity : < 10⁷ Ω based on the BS ISO 2878 : 2005 standard

Surface resistivity : < 10⁸ Ω based on the BS ISO 14309 : 2011 standard

Volume resistivity : < 10⁸ Ω based on the BS ISO 14309 : 2011 standard



Thanks to Mersen's expertise in lining technologies (PFA injection, extrusion of fine PTFE powders), Mersen has optimised its manufacturing processes and PTFE / PFA thicknesses in order to limit the permeability rate.

OPTIMIZING THE LINER THICKNESS - PERMEABILITY

SEVERAL FACTORS HAVE AN INFLUENCE :

- ▶ **Thickness of the liner is the most significant factor.** The chart below shows the sharp decrease of permeability versus thickness.
- ▶ **Size of the ions or molecules :** the Helium permeability curve shows the ability of a very small molecule such as helium to pass through the PTFE / PFA.
- ▶ **Chemical nature of the product :** any chemical similarity between the material passing through and the material passed through increases permeability.
- ▶ **Temperature and pressure:** permeability increases with temperature and pressure.

EXAMPLES OF PERMEABILITY CURVES :

PTFE / PFA permeability curve

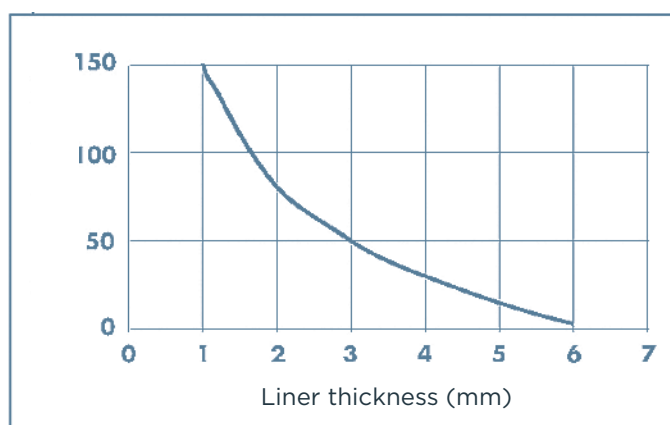

Helium permeability PTFE / PFA curve

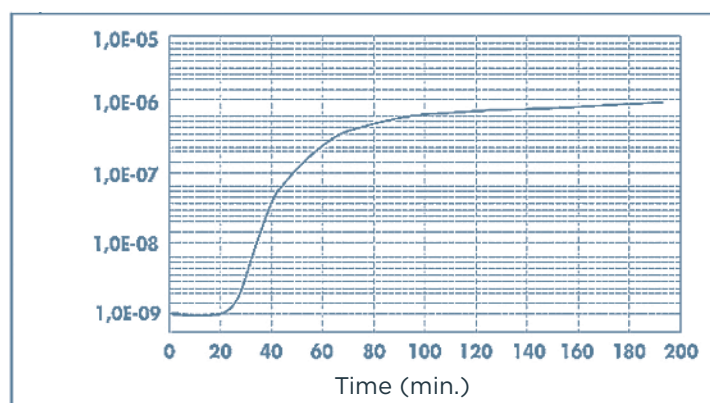

STEEL PARTS

COMPONENTS

The table below shows the various steel components used for manufacturing our standard pieces. 3.1 mill certificates in accordance with EN 10204 are available on request.

ASTM compliant steel grades, low temperature or stainless steel grades can be supplied on request. Please contact us for more information.

DESCRIPTION	PIPES / BODIES		FLANGES	
	DIMENSIONAL STANDARD	GRADE	DIMENSIONAL STANDARD	MIN. GRADE
SPOOLS	EN 10217	P 235 GH / EN 10217	EN 1092-1	P 250 GH / EN 10222
ELBOWS	EN 10253	P 235 GH / EN 10217	EN 1092-1	P 250 GH / EN 10222
TEES AND CROSSES	EN 10217	P 235 GH / EN 10217	EN 1092-1	P 250 GH / EN 10222
CONCENTRIC REDUCERS	EN 10253	P 235 GH / EN 10217	EN 1092-1	P 250 GH / EN 10222
REDUCING FLANGES			EN 1092-1	P 265 GH / EN 10028
SPACERS				P 265 GH / EN 10028
INSTRUMENT TEES	EN 10217	P 355 NH / EN 10216 - P265GH / EN 10028	EN 1092-1	P 250 GH / EN 10222

WELDING

Welds are prepared by EN and ASME-qualified welders and processes such as GMAW, FCAW, GTAW and SAW. Quality of welds meets the requirements of the EN ISO 5817 level B standard.

VENT HOLES

THE STEEL PARTS OF THE PTFE / PFA LINED FITTINGS ARE DRILLED WITH VENT HOLES IN ORDER TO :

- ▶ Prevent any back pressure between the metallic housing and the liner.
- ▶ Detect any leakage during pressure tests.
- ▶ Quickly detect any sign of corrosion.

Spools with length below 500 mm have one 3 mm diameter vent hole in the middle of the piece. Those above 500 mm are fitted with two vent holes located about 150 mm from each end. The fittings have at least one 3 mm diameter vent hole. Reducing flanges, blind flanges and spacers do not have any vent holes. In the case of particular specifications or thermal insulation piping, vent bosses can be welded to the vent holes.

VENT BOSSES

If vent holes must be identified quickly or when the piping is thermal insulated, a coupling can be welded on to the vent holes. In the case of different thermal insulation thicknesses, an extension stem can be screwed on to the coupling.

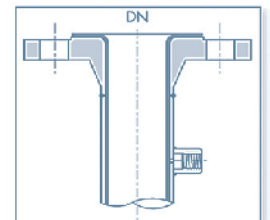

ELECTRICAL CONTINUITY

The electrical continuity of lined piping can be ensured by connecting each individual component together by using conductors linked to earthing lugs.

The latter are welded in the middle of the steel part for fittings and spools below 500 mm long and at about 150 mm from the back side of each flange for spools above 500 mm long. Types A or B earthing lugs can be proposed on request. Standard materials are 304 or 316 stainless steel grades.

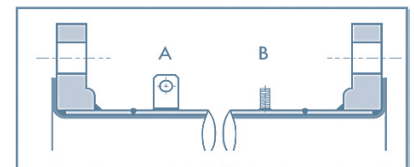

Other materials can be supplied on request.

PAINTING

The standard coating is a 60 µm minimum thick zinc epoxy primer coating on sand blasted steel, in accordance with the S.A 2.5 cleanliness level. Other surface preparations, undercoats or topcoats can be applied on request.

LINED COMPONENTS

DIMENSIONAL TOLERANCES

The lined pieces and their dimensions are indicated in pages 15 to 30.
All the lined pieces are built using the following tolerances :

	DIMENSION	DIMENSIONAL TOLERANCE	ANGULAR TOLERANCE
LENGTHS	0 - 315 mm	+0; -3 mm	± 0.5°
	315 - 1000 mm	+0; -4 mm	± 0.5°
	1000 - 6000 mm	+0; -5 mm	± 0.5°
DIAMETERS	DN 25 - 100	+0; -3 mm	± 0.5°
	DN 125 - 200	+0; -4 mm	± 0.5°
	DN 250 - 600	+0; -5 mm	± 0.5°

Tolerance for PTFE / PFA : 5%

TEMPERATURE CYCLE TESTS

The pieces tested undergo 100 alternate steam / cold water cycles, according to the ASTM F1545 standard. Steam is absorbed by the liner under the influence of both temperature and pressure. Vacuum resistance of the liner is then proved due to significant mechanical stresses caused by the sudden pressure drop combined with fast cooling.

VACUUM RESISTANCE

DN	15	20	25	32	40	50	65	80	100	125	200	250	300	350	400
ARMYLOR® G										no vacuum					
ARMYLOR® V	Vacuum 2 Torr 200°C											2 Torr 100°C			

Units : 760 Torrs = 760 mmHg = 1 bar = 1 kg/cm² = 10⁵ Pa = 14.7 Psi

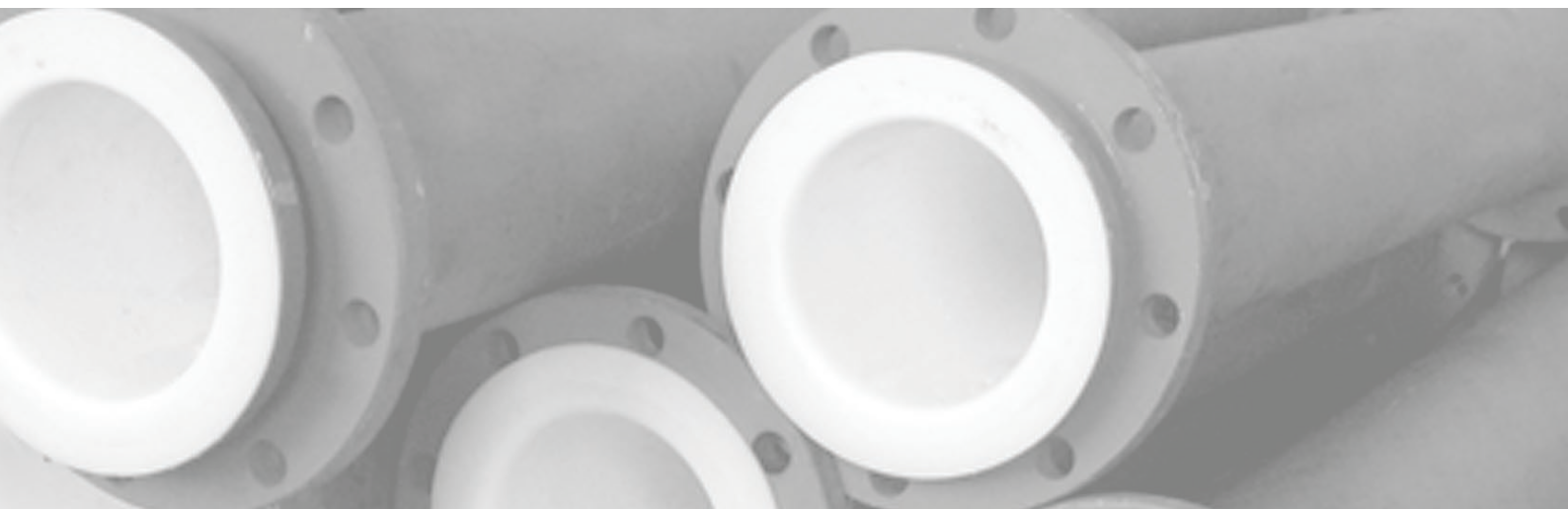

QUALITY CONTROL

INSPECTIONS AND TESTS PROGRAM

MERSEN manufactures PTFE-lined piping and fittings compliant with the the European Pressure Equipment Directive 2014/68/UE. Type agreements are awarded by Mersen's Notified Body for the whole range of ARMYLOR® products. In addition to assessments carried out by Third Parties and continuous internal audits, a complete inspection and tests program is set during the entire manufacturing process :

- **Raw material (fluoropolymers)** : acceptance criteria at receiving inspections, physical properties of the liners monitored throughout the manufacturing process...
- **Spark tests are performed on each PTFE and PFA-lined piece in the following conditions :**
voltage of $5000 * E$ (E = thickness of liner in mm) with a maximum of 25000 V.
- **Dimensional and visual examination of the liners and steel parts :**
the weld aspect, the overall dimensions, the size of the collars, the liner thickness, the absence of surface defects and the painting thickness are checked.
- **Non-destructive examinations** are carried out when required by the applicable standards or on request. RT and PT are performed by level II qualified personnel.
- **Pressure tests :** depending on the lining process, a hydrostatic or a pneumatic test is performed. A hydrostatic test is performed on pieces fitted with vent holes, injected or produced from tubes.

TRACEABILITY AND MARKING

IN ADDITION TO THE INSPECTIONS AND TESTS PROGRAM, A FULL TRACEABILITY SYSTEM OF MATERIALS IS IMPLEMENTED :

- ▶ **Steel parts** : a coded marking system with unique traceability to the mill certificates is used. Marking transfers by Mersen qualified personnel are approved by Mersen's Notified Body.
- ▶ **Finished product** : in addition to the identification of label sticked on each item, the following information is stamped:
 - the applicable standard
 - the lining material
 - the manufacturing year and month
 - the CE mark and Notified Body number (when applicable)
 - the serial number
- ▶ **Traceability of documents** : total traceability is ensured with the same method for both steel and lining materials.

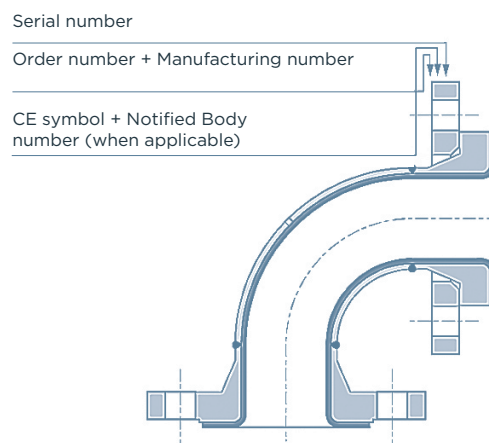

INSTALLATION PROCEDURE

Installation and maintenance instructions are provided in the user's manual delivered with the products. Specific items are highlighted here after.

PRECAUTIONS

The lined steel components are delivered with wooden or plastic blanks installed to protect the PTFE / PFA flange faces. Remove these protective blanks when the components are about to be connected only : they shall be refitted after each inspection and when the piece is withdrawn from the installation. Once the blanks have been removed, the greatest care is required : no contact with the ground, absence of any sharp object that could damage the liner. **Never weld on lined parts.**

CLEANING

Flared surface must be carefully cleaned prior to connection.

BOLT TIGHTENING

The assembly of PTFE / PFA lined components does not require any gaskets except when materials of different natures are being coupled or during successive assembling and dismantling operations.

TIGHTENING BOLTS :

- ▶ **Insert** the washers.
- ▶ **Clean** and grease the bolts.
- ▶ **Tighten** nuts by hands.
- ▶ **Tighten** each bolt using a torque wrench, keeping to the torque values specified in the table beside.
- ▶ Cross-tightening as with any flange connection.

Tightening torque values are given for PTFE / PFA and may vary depending on greasing and the condition of the nuts and bolts.

Values are given for PN 10 flanges. They are indicated for room temperature and must always be checked in cold conditions, after 24 hours of operation, then checked periodically.

THE TIGHTENING TORQUE VALUES INDICATED BESIDE APPLY TO :

Class 8.8 steel nuts

(resistant to 800 N/mm² rupture, elasticity limit of 640 N/mm²).

0.12. nut friction coefficient.

DN	BOLTS mm	TORQUE N.m
DN 25	4 x M12	30
DN 32	4 x M16	45
DN 40	4 x M16	60
DN 50	4 x M16	80
DN 65	8 x M16	100
DN 80	8 x M16	60
DN 100	8 x M16	70
DN 125	8 x M16	90
DN 150	8 x M20	130
DN 200	8 x M20	180
DN 250	12 x M20	160
DN 300	12 x M20	210
DN 350	16 x M20	260
DN 400	16 x M24	330
DN 450	20 x M24	290
DN 500	20 x M24	330
DN 600	20 x M27	460

BOLT LENGTHS

The table below specifies the recommended lengths of threaded stems for the various assemblies.

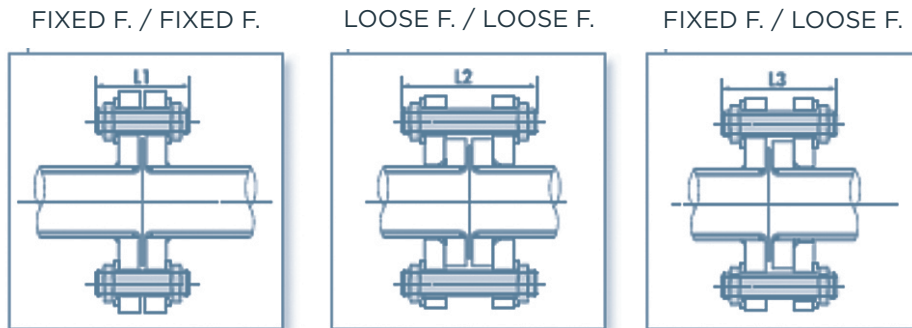

THE DIMENSIONS INDICATED REFER TO :

- ▶ A tightening torque equal to 1/3 the diameter of the threaded stems.
- ▶ A nut height equal to the diameter of the threaded stems.

VENT HOLES

Vent holes must not be obstructed by thermal insulation or painting. Where thermal insulation is fitted, vent extensions should be provided. When pipes are operated for the first time, air or water trapped inside at the moment of assembly may escape through the vent holes. It is recommended, during periodic inspection, to check that no trace of leakage is visible around the vent holes. The latter also act as corrosion indicators.

WEIGHT

The weight (kg) of each piece is indicated on the corresponding tables. Due to the various construction methods, the weights are typical values only. The tolerance is +/- 10%.

SUPPORTS

Elements must be supported using collars that are not welded on the lined piping. **Never weld on lined parts.** However, supporting elements may be welded prior to lining.

DN	L1 mm	L2 mm	L3 mm
DN 15	75	95	85
DN 20	80	100	90
DN 25	80	105	90
DN 32	90	115	105
DN 40	90	115	105
DN 50	95	120	105
DN 65	95	125	110
DN 80	100	130	115
DN 100	105	130	115
DN 125	110	135	120
DN 150	120	150	135
DN 200	125	155	140
DN 250	130	165	145
DN 300	130	175	150
DN 350	135	180	155
DN 400	160	205	175
DN 450	170	205	175
DN 500	170	230	190
DN 600	170	235	190

CODING SYSTEM AND REFERENCES

Each element has its own unique reference which allows its identification.

This reference is composed on 16 alphanumeric characters. In some cases, the character can be «-» if refers to standard. The references that are mentioned in the dimensional tables are the standard ones.

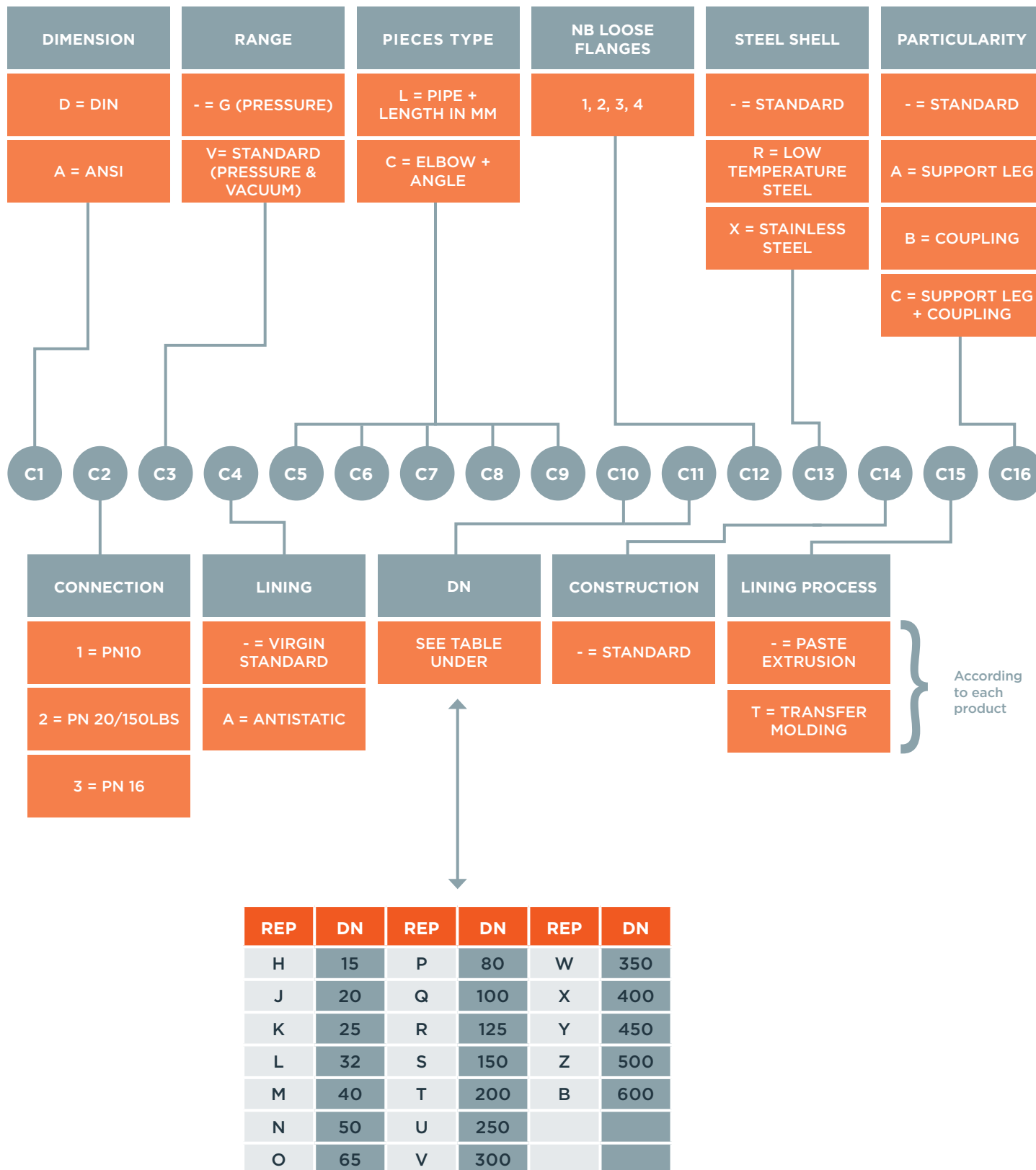

PRODUCTS DATA SHEETS

DIN FLANGES PN 10 AND PIPES [p.15](#)

FLANGED SPOOLS [p.16](#)

ELBOWS [p.17](#)

EQUAL TEES [p.18](#)

REDUCING TEES [p.19-20](#)

CONCENTRIC & ECCENTRIC REDUCERS [p.21](#)

REDUCING FLANGES [p.22-24](#)

INSTRUMENT TEES [p.25](#)

CROSSES [p.26](#)

SPACERS [p.28](#)

SPECTACLE BLINDS [p.29](#)

BLIND FLANGES & LATERAL TEES [p.30](#)

DIN FLANGES PN 10 AND PIPES

DIMENSIONAL TOLERANCES

The whole range of flanged products from DN15 to DN600 can be equipped with loose or fixed flanges on request.

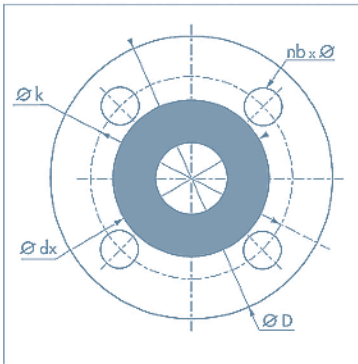

Flange (front view)

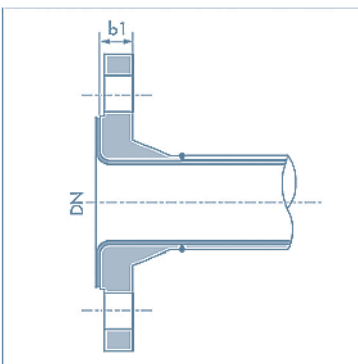

EN 1092-1 type 11-A Welding neck type W (Fixed)

DN	DIAMETERS				THICKNESS				DRILLING PN10			STEEL TUBES		
	D	dx*	dy	k	b1	b2	b3	b4	holes		bolting	d1	s	
	mm	mm	mm	mm	mm	mm	mm	mm	nb	x	ø		mm	mm
15	95	45	45	65	14	14	14	10	4	x	14	M12	26.9	2.3
20	105	58	55	75	16	14	16	12	4	x	14	M12	26.9	2.3
25	115	68	55	85	16	16	16	12	4	x	14	M12	33.7	2.6
32	140	78	67	100	16	16	16	12	4	x	18	M16	42.4	2.6
40	150	88	80	110	16	16	16	12	4	x	18	M16	48.3	2.6
50	165	102	95	125	18	16	18	14	4	x	18	M16	60.3	2.9
65	185	122	118	145	18	16	18	14	8	x	18	M16	76.1	2.9
80	200	138	130	160	20	18	20	16	8	x	18	M16	88.9	3.2
100	220	158	158	180	20	18	20	16	8	x	18	M16	114.3	3.6
125	250	188	188	210	22	18	22	18	8	x	18	M16	139.7	4.0
150	285	212	212	240	22	18	22	18	8	x	22	M20	168.3	4.5
200	340	268	268	295	24	20	24	20	8	x	22	M20	219.1	6.3
250	395	320	320	350	26	22	26	22	12	x	22	M20	273.0	6.3
300	445	370	370	400	26	26	26	22	12	x	22	M20	323.9	7.1
350	505	430	430	460	26	28	28	22	16	x	22	M20	355.6	8.0
400	565	482		515	26	32	32	24	16	x	26	M24	406.4	8.8
450	615	532		565	/	/	38	24	20	x	26	M24	457.2	9.5
500	670	585		620	28	38	38	26	20	x	26	M24	508.0	9.5
600	780	685		725	28	44	40	26	20	x	30	M27	609.6	9.5

* Tolerance 5%

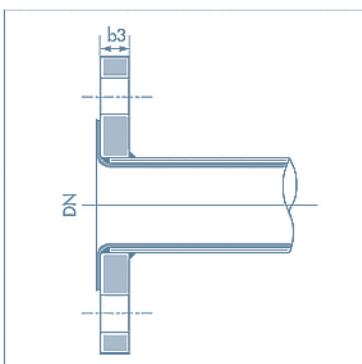

EN 1092-1 type 01-A Slip-on Type P (Fixed)

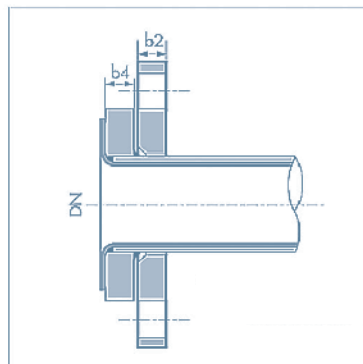

EN 1092-1 type 02-A Collar + slip-on type P (loose)

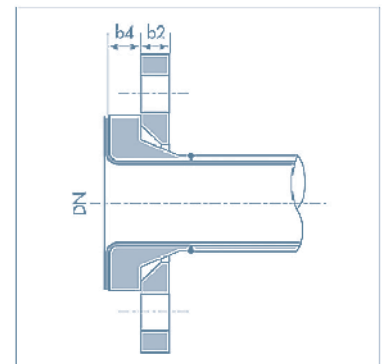

EN 1092-1 type 04-A Collar + slip-on type W

FLANGED SPOOLS



LINING

- ▶ VIRGIN PTFE :
DN 15 - DN 600
- ▶ ANTISTATIC PTFE, C4 = A :
DN 15 - DN 400

Standard construction: 1 fixed flange, 1 loose flange

DN	L min.	L max.	Weight kg/m	Pair flanges weight	REFERENCE															
	mm	mm			1	2	3	4	5	6	7	8	9	10	11	12	13	14	15	16
15	85	6000	1.8	1.4	D	3	V	-	L	x	x	x	x	H						
20	85	6000	1.8	1.9	D	3	V	-	L	x	x	x	x	J						
25	85	6000	2.8	2.5	D	3	V	-	L	x	x	x	x	K						
32	85	6000	3.2	3.7	D	3	V	-	L	x	x	x	x	L						
40	90	6000	3.9	4.2	D	3	V	-	L	x	x	x	x	M						
50	100	6000	5.3	5.5	D	3	V	-	L	x	x	x	x	N						
65	100	6000	6.7	6.7	D	3	V	-	L	x	x	x	x	O						
80	110	6000	9.2	8.4	D	3	V	-	L	x	x	x	x	P						
100	120	6000	12	10	D	3	V	-	L	x	x	x	x	Q						
125	120	6000	16	13	D	3	V	-	L	x	x	x	x	R						
150	120	6000	21	16	D	3	V	-	L	x	x	x	x	S						
200	130	6000	41	23	D	1	V	-	L	x	x	x	x	T						
250	150	6000	56	31	D	1	V	-	L	x	x	x	x	U						
300	150	6000*	63	38	D	1	V	-	L	x	x	x	x	V						
350	150	5000	78	51	D	1	-	-	L	x	x	x	x	W						
400	150	3500	97	65	D	1	-	-	L	x	x	x	x	X						
450	150	6000	104	85	D	1	-	-	L	x	x	x	x	Y						
500	160	6000	133	90	D	1	-	-	L	x	x	x	x	Z						
600	180	4500	161	134	D	1	-	-	L	x	x	x	x	B						

*For vacuum thickness, L max = 4500 and xxx = length in mm.

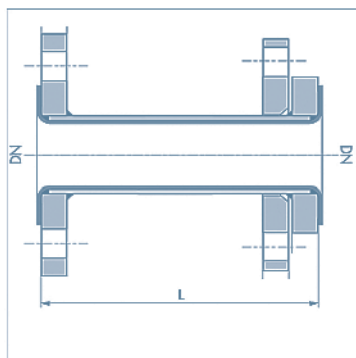

Type P construction

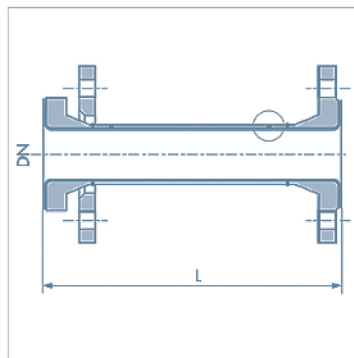

Type W construction

ELBOWS



LINING

- ▶ VIRGIN PTFE : DN 15 - DN 600
- ▶ ANTISTATIC PTFE, C4 = A : DN 15 - DN 400

Standard construction :

- 1 fixed flange + 1 loose flange up to DN150
- 2 fixed flanges from DN 200 up to DN600

DN	L (mm)				Weight (kg)				REFERENCE																
	$\alpha=90^\circ$	$\alpha=45^\circ$	$\alpha=60^\circ$	$\alpha=30^\circ$	90°	45°	60°	30°	1	2	3	4	5	6	7	8	9	10	11	12	13	14	15	16	
15	85	59			1.7	1.5	1.6	1.5	D	3	V	-	C	•	•	-	-	H							
20	95	65	75	70	2.1	2.2	2.2	2.1	D	3	V	-	C	•	•	-	-	J							
25	110	70	80	60	2.9	2.6	2.7	2.6	D	3	V	-	C	•	•	-	-	K							
32	130	80	95	65	4.2	3.9	4.0	3.8	D	3	V	-	C	•	•	-	-	L							
40	150	90	110	75	4.9	4.5	4.6	4.3	D	3	V	-	C	•	•	-	-	M							
50	120	80	90	65	6.3	5.8	5.9	5.6	D	3	V	-	C	•	•	-	-	N							
65	140	85	100	70	8.1	7.2	7.5	6.9	D	3	V	-	C	•	•	-	-	O							
80	165	100	120	80	10	9.3	9.7	8.9	D	3	V	-	C	•	•	-	-	P							
100	205	115	140	95	13	11	11	10	D	3	V	-	C	•	•	-	-	Q							
125	245	135	170	110	19	15	16	14	D	3	V	-	C	•	•	-	-	R							
150	285	150	190	120	25	20	21	18	D	3	V	-	C	•	•	-	-	S							
200	365	190	240	145	45	33	37	28	D	1	V	-	C	•	•	-	-	T							
250	450*	225	285	165	65	46	52	39	D	1	V	-	C	•	•	-	-	U							
300	525*	260	330	185	89	60	69	50	D	1	V	-	C	•	•	-	-	V							
350	600*	290	375	210	126	86	120	74	D	1	-	-	C	•	•	-	-	W							
400	680*	325	425	235	175	119	160	102	D	1	-	-	C	•	•	-	-	X							
450	680*	350	415	205	179	139	169	125	D	1	-	-	C	•	•	-	-	Y							
500	830*	390	795*	275	376	188	230	162	D	1	-	-	C	•	•	-	-	Z							
600	974*	412	950*	325	567	292	550	212	D	1	-	-	C	•	•	-	-	B							

* : * 2 parts or 3 parts construction

• : Angle in degree : 90, 45, 60 or 30

Special angle available on request

The 30 ° and 60° elbows are not included in the DIN 2848 standard

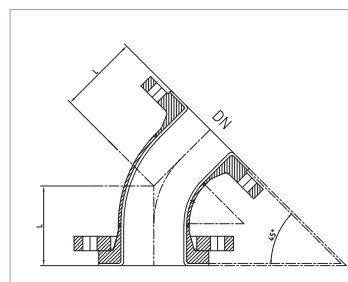
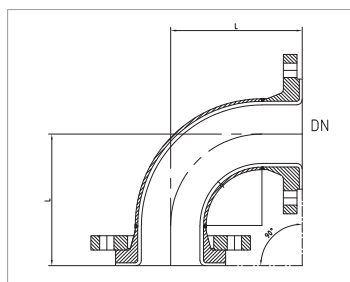

EQUAL TEES

LINING

- ▶ VIRGIN PFA : DN 15 - DN 100
- ▶ ANTISTATIC PFA : DN 15 - DN 100, C4 = A
- ▶ VIRGIN PTFE : DN 125 - DN 600
- ▶ ANTISTATIC PTFE : DN 125 - DN 400, C4 = A

Standard construction :

- 1 fixed flange on nozzle + 2 loose flanges on body up to DN150
- 3 fixed flanges from DN 200 up to DN600

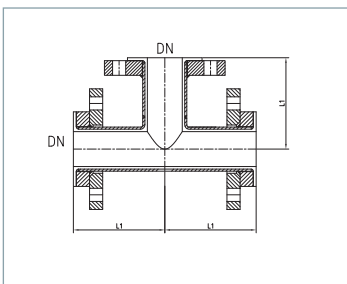

Construction in 1 part

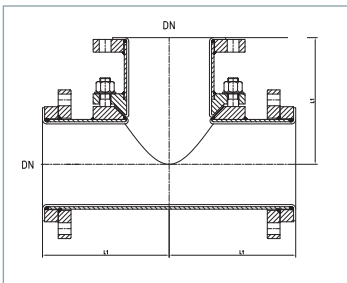

Construction in 2 parts

DN	L1 mm	Weight kg	REFERENCE															
			1	2	3	4	5	6	7	8	9	10	11	12	13	14	15	16
15	85	2.6	D	3	V	-	T	E	-	-	-	H	-	2	-	-	-	-
20	95	3.6	D	3	V	-	T	E	-	-	-	J	-	2	-	-	-	-
25	110	4.5	D	3	V	-	T	E	-	-	-	K	-	2	-	-	-	-
32	130	6.6	D	3	V	-	T	E	-	-	-	L	-	2	-	-	-	-
40	150	7.7	D	3	V	-	T	E	-	-	-	M	-	2	-	-	-	-
50	120	9.7	D	3	V	-	T	E	-	-	-	N	-	2	-	-	-	-
65	140	12	D	3	V	-	T	E	-	-	-	O	-	2	-	-	-	-
80	165	16	D	3	V	-	T	E	-	-	-	P	-	2	-	-	-	-
100	205	20	D	3	V	-	T	E	-	-	-	Q	-	2	-	-	-	-
125*	245	30	D	3	V	-	T	E	-	-	-	R	-	2	-	-	-	-
150*	285	40	D	3	V	-	T	E	-	-	-	S	-	2	-	-	-	-
200*	365	74	D	1	V	-	T	E	-	-	-	T	-	-	-	-	-	-
250*	450	120	D	1	V	-	T	E	-	-	-	U	-	-	-	-	-	-
300*	525	162	D	1	V	-	T	E	-	-	-	V	-	-	-	-	-	-
350*	600	231	D	1	-	-	T	E	-	-	-	W	-	-	-	-	-	-
400*	680	320	D	1	-	-	T	E	-	-	-	X	-	-	-	-	-	-
450*	680	385	D	1	-	-	T	E	-	-	-	Y	-	-	-	-	-	-
500*	830	473	D	1	-	-	T	E	-	-	-	Z	-	-	-	-	-	-
600*	830	552	D	1	-	-	T	E	-	-	-	B	-	-	-	-	-	-

*2 parts construction

REDUCING TEES

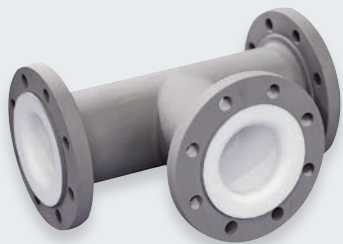

LINING

- ▶ VIRGIN PFA : DN 20 - DN 100
- ▶ ANTISTATIC PFA : DN 20 - DN 100, C4 = A
- ▶ VIRGIN PTFE : DN 125 - DN 600
- ▶ ANTISTATIC PTFE : DN 125 - DN 600, C4 = A

Standard construction :

■ 1 fixed flange on nozzle + 2 loose flanges on body up to DN150

■ 3 fixed flanges from DN 200 up to DN600

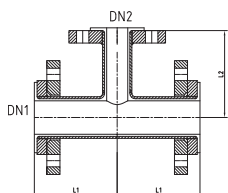

Construction in 1 part

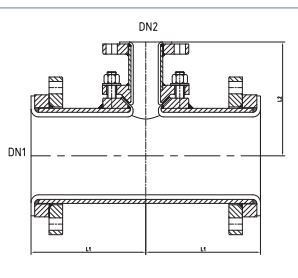

Construction in 2 parts

DN1	DN2	L1 mm	L2 mm	Weight kg	REFERENCE															
					1	2	3	4	5	6	7	8	9	10	11	12	13	14	15	16
20	15	95	85	3.2	D	3	V	-	T	R	-	-	-	J	H	2	-	-	-	-
	25	110	85	3.8	D	3	V	-	T	R	-	-	-	K	H	2	-	-	-	-
25	15	110	95	4.1	D	3	V	-	T	R	-	-	-	K	J	2	-	-	-	-
	20	110	95	4.1	D	3	V	-	T	R	-	-	-	K	J	2	-	-	-	-
32	15	130	85	5.3	D	3	V	-	T	R	-	-	-	L	H	2	-	-	-	-
	20	130	95	5.6	D	3	V	-	T	R	-	-	-	L	J	2	-	-	-	-
40	25	130	110	5.9	D	3	V	-	T	R	-	-	-	L	K	2	-	-	-	-
	20	130	110	5.9	D	3	V	-	T	R	-	-	-	L	K	2	-	-	-	-
40	20	150	95	6.4	D	3	V	-	T	R	-	-	-	M	J	2	-	-	-	-
	25	150	110	6.7	D	3	V	-	T	R	-	-	-	M	K	2	-	-	-	-
50	32	150	130	7.4	D	3	V	-	T	R	-	-	-	M	L	2	-	-	-	-
	20	150	130	7.4	D	3	V	-	T	R	-	-	-	M	L	2	-	-	-	-
50	25	120	110	8.0	D	3	V	-	T	R	-	-	-	N	K	2	-	-	-	-
	32	120	130	8.7	D	3	V	-	T	R	-	-	-	N	L	2	-	-	-	-
65	40	120	150	9.1	D	3	V	-	T	R	-	-	-	N	M	2	-	-	-	-
	25	120	150	9.1	D	3	V	-	T	R	-	-	-	N	M	2	-	-	-	-
65	32	140	110	9.9	D	3	V	-	T	R	-	-	-	O	K	2	-	-	-	-
	40	140	130	10	D	3	V	-	T	R	-	-	-	O	L	2	-	-	-	-
80	50	140	150	11	D	3	V	-	T	R	-	-	-	O	M	2	-	-	-	-
	25	140	150	11	D	3	V	-	T	R	-	-	-	O	M	2	-	-	-	-
80	40	165	110	12	D	3	V	-	T	R	-	-	-	P	K	2	-	-	-	-
	50	165	120	14	D	3	V	-	T	R	-	-	-	P	N	2	-	-	-	-
100	65	165	140	15	D	3	V	-	T	R	-	-	-	P	O	2	-	-	-	-
	40	205	150	16	D	3	V	-	T	R	-	-	-	Q	M	2	-	-	-	-
100	50	205	120	17	D	3	V	-	T	R	-	-	-	Q	N	2	-	-	-	-
	65	205	140	18	D	3	V	-	T	R	-	-	-	Q	O	2	-	-	-	-
125*	80	205	165	19	D	3	V	-	T	R	-	-	-	Q	P	2	-	-	-	-
	65	245	140	24	D	3	V	-	T	R	-	-	-	R	O	-	-	-	-	-
125*	80	245	165	25	D	3	V	-	T	R	-	-	-	R	P	-	-	-	-	-
	100	245	205	27	D	3	V	-	T	R	-	-	-	R	Q	2	-	-	-	-

*2 parts construction

REDUCING TEES



LINING

- ▶ VIRGIN PTFE : DN 150 - DN 600
- ▶ ANTISTATIC PTFE, C4 = A : DN 150 - DN 400

Standard construction :

- 1 fixed flange on nozzle + 2 loose flanges on body up to DN150
- 3 fixed flanges from DN 200 up to DN600

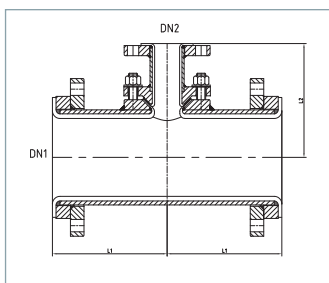

Construction in 2 parts

DN1	DN2	L1 mm	L2 mm	Weight kg	REFERENCE															
					1	2	3	4	5	6	7	8	9	10	11	12	13	14	15	16
150*	50	285	120	31	D	3	V	-	T	R	-	-	-	S	N	2	-	-	-	
	65	285	140	32	D	3	V	-	T	R	-	-	-	S	O	2	-	-	-	
	80	285	165	33	D	3	V	-	T	R	-	-	-	S	P	2	-	-	-	
	100	285	205	34	D	3	V	-	T	R	-	-	-	S	Q	2	-	-	-	
	125	285	245	37	D	3	V	-	T	R	-	-	-	S	R	2	-	-	-	
200*	100	365	205	58	D	1	V	-	T	R	-	-	-	T	Q	-	-	-	-	
	125	365	245	60	D	1	V	-	T	R	-	-	-	T	R	-	-	-	-	
	150	365	285	64	D	1	V	-	T	R	-	-	-	T	S	-	-	-	-	
250*	100	450	205	81	D	1	V	-	T	R	-	-	-	U	Q	-	-	-	-	
	125	450	245	84	D	1	V	-	T	R	-	-	-	U	R	-	-	-	-	
	150	450	285	87	D	1	V	-	T	R	-	-	-	U	S	-	-	-	-	
	200	450	365	96	D	1	V	-	T	R	-	-	-	U	V	-	-	-	-	
300*	100	525	205	113	D	1	V	-	T	R	-	-	-	V	Q	-	-	-	-	
	150	525	285	116	D	1	V	-	T	R	-	-	-	V	S	-	-	-	-	
	200	525	365	125	D	1	V	-	T	R	-	-	-	V	V	-	-	-	-	
	250	525	450	148	D	1	V	-	T	R	-	-	-	V	U	-	-	-	-	
350*	200	600	365	178	D	1	-	-	T	R	-	-	-	W	V	-	-	-	-	
	250	600	450	191	D	1	-	-	T	R	-	-	-	W	U	-	-	-	-	
	300	600	525	205	D	1	-	-	T	R	-	-	-	W	V	-	-	-	-	
400	250	600	450	247	D	1	-	-	T	R	-	-	-	X	U	-	-	-	-	
	300	680	525	261	D	1	-	-	T	R	-	-	-	X	V	-	-	-	-	
	350	680	600	287	D	1	-	-	T	R	-	-	-	X	X	-	-	-	-	
450*	300	680	525	324	D	1	-	-	T	R	-	-	-	Y	V	-	-	-	-	
	350	680	600	357	D	1	-	-	T	R	-	-	-	Y	W	-	-	-	-	
500*	300	830	525	282	D	1	-	-	T	R	-	-	-	Z	V	-	-	-	-	
	350	830	600	308	D	1	-	-	T	R	-	-	-	Z	W	-	-	-	-	
	400	830	680	340	D	1	-	-	T	R	-	-	-	Z	X	-	-	-	-	
	450	830	680	368	D	1	-	-	T	R	-	-	-	Z	Y	-	-	-	-	
600*	400	830	680	465	D	1	-	-	T	R	-	-	-	B	X	-	-	-	-	
	450	830	830	495	D	1	-	-	T	R	-	-	-	B	Y	-	-	-	-	
	500	830	830	525	D	1	-	-	T	R	-	-	-	B	Z	-	-	-	-	

*2 parts construction

REDUCING FLANGES



LINING

- ▶ VIRGIN PTFE/PFA : DN 100 - DN 250
- ▶ ANTI STATIC PTFE/PFA, , C4 = A : DN 100 - DN 250

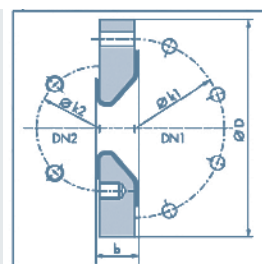

Tapped hole / through hole type A

DN1	DN2	øD mm	b mm	DN1			DN2			Type	Weight kg	REFERENCE																		
				ø k1 mm	Holes		ø k2 mm	Holes				1	2	3	4	5	6	7	8	9	10	11	12	13	14	15	16			
					nb	ø		Bolting	nb																			Bolting		
100	15	220	45	180	8 x	18		65	4 x	M12	A	11	D	3	V	-	B	R	-	-	-	Q	H							
	20	220	45	180	8 x	18		75	4 x	M12	A	11	D	3	V	-	B	R	-	-	-	Q	J							
	25	220	45	180	8 x	18		85	4 x	M12	A	11	D	3	V	-	B	R	-	-	-	Q	K							
	32	220	45	180	8 x	18		100	4 x	M16	A	11	D	3	V	-	B	R	-	-	-	Q	L							
	40	220	45	180	8 x	18		110	4 x	M16	A	11	D	3	V	-	B	R	-	-	-	Q	M							
	50	220	45	180	8 x		M16	125	4 x	M16	B	10	D	3	V	-	B	R	-	-	-	Q	N							
	65	220	45	180	8 x		M16	145	4 x	M16	B	10	D	3	V	-	B	R	-	-	-	Q	O							
	80	220	45	180	8 x		M16	160	8 x	M12	C	10	D	3	V	-	B	R	-	-	-	Q	P							
125	32	250	45	210	8 x	18		100	4 x	M16	A	13	D	3	V	-	B	R	-	-	-	R	L							
	40	250	45	210	8 x	18		110	4 x	M16	A	13	D	3	V	-	B	R	-	-	-	R	M							
	50	250	45	210	8 x	18		125	4 x	M16	A	12	D	3	V	-	B	R	-	-	-	R	N							
	65	250	45	210	8 x		M16	145	4 x	M16	B	12	D	3	V	-	B	R	-	-	-	R	O							
	80	250	45	210	8 x		M16	160	8 x	M16	B	12	D	3	V	-	B	R	-	-	-	R	P							
	100	250	45	210	8 x		M16	180	8 x	M16	C	12	D	3	V	-	B	R	-	-	-	R	Q							
150	25	285	45	240	8 x	22		85	4 x	M12		17	D	3	V	-	B	R	-	-	-	S	K							
	32	285	45	240	8 x	22		100	4 x	M16	A	17	D	3	V	-	B	R	-	-	-	S	L							
	40	285	45	240	8 x	22		110	4 x	M16	A	17	D	3	V	-	B	R	-	-	-	S	M							
	50	285	45	240	8 x	22		125	4 x	M16	A	17	D	3	V	-	B	R	-	-	-	S	N							
	65	285	45	240	8 x	22		145	4 x	M16	A	17	D	3	V	-	B	R	-	-	-	S	O							
	80	285	45	240	8 x	22		160	8 x	M16	A	16	D	3	V	-	B	R	-	-	-	S	P							
	100	285	45	240	8 x		M20	180	8 x	M16	B	15	D	3	V	-	B	R	-	-	-	S	Q							
	125	285	45	240	8 x		M20	210	8 x	M20	B	14	D	3	V	-	B	R	-	-	-	S	R							
200	25	340	45	295	8 x	22		85	4 x	M12	C	25	D	1	V	-	B	R	-	-	-	T	K							
	32	340	45	295	8 x	22		100	4 x	M16	A	25	D	1	V	-	B	R	-	-	-	T	L							
	40	340	45	295	8 x	22		110	4 x	M16	A	25	D	1	V	-	B	R	-	-	-	T	M							
	50	340	45	295	8 x	22		125	4 x	M16	A	25	D	1	V	-	B	R	-	-	-	T	N							
	65	340	45	295	8 x	22		145	4 x	M16	A	25	D	1	V	-	B	R	-	-	-	T	O							
	80	340	45	295	8 x	22		160	8 x	M16	A	24	D	1	V	-	B	R	-	-	-	T	P							
	100	340	45	295	8 x	22		180	8 x	M16	A	23	D	1	V	-	B	R	-	-	-	T	Q							
	125	340	45	295	8 x	22		210	8 x	M20	B	22	D	1	V	-	B	R	-	-	-	T	R							
	150	340	45	295	8 x		M20	240	8 x	M20	B	20	D	1	V	-	B	R	-	-	-	T	S							
	250	40	395	45	350	12 x	22		110	4 x	M16	A	34	D	1	V	-	B	R	-	-	-	U	M						
50		395	45	350	12 x	22		125	4 x	M16	A	34	D	1	V	-	B	R	-	-	-	U	N							
65		395	45	350	12 x	22		145	4 x	M16	A	34	D	1	V	-	B	R	-	-	-	U	O							
80		395	45	350	12 x	22		160	8 x	M16	A	33	D	1	V	-	B	R	-	-	-	U	P							

CROSSES



LINING

- ▶ VIRGIN PFA : DN 15 - DN 100
- ▶ ANTISTATIC PFA : DN 15 - DN 100
- ▶ VIRGIN PTFE : DN 125 - DN 600
- ▶ ANTISTATIC PTFE / DN 125 - DN 400

Standard construction :

- DN 15 to DN150
2 loose flanges on body, 2 fixed flanges on nozzles
- DN200 to 600 : 4 fixed flanges

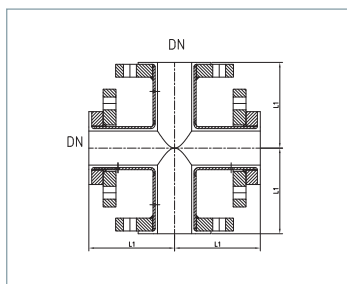

Construction 1 part

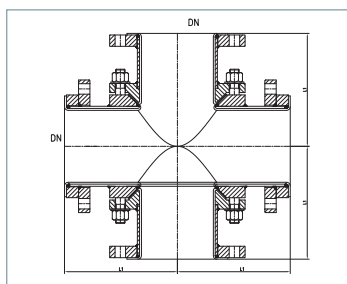

* construction in 3 parts

DN	L1 mm	Weight kg	REFERENCE															
			1	2	3	4	5	6	7	8	9	10	11	12	13	14	15	16
15	85	3.4	D	3	V	-	X	E	-	-	-	H	-	2				
20	95	4.7	D	3	V	-	X	E	-	-	-	J	-	2				
25	110	5.9	D	3	V	-	X	E	-	-	-	K	-	2				
32	130	8.8	D	3	V	-	X	E	-	-	-	L	-	2				
40	150	10	D	3	V	-	X	E	-	-	-	M	-	2				
50	120	12	D	3	V	-	X	E	-	-	-	N	-	2				
65	140	16	D	3	V	-	X	E	-	-	-	O	-	2				
80	165	21	D	3	V	-	X	E	-	-	-	P	-	2				
100	205	27	D	3	V	-	X	E	-	-	-	Q	-	2				
125*	245	39	D	3	V	-	X	E	-	-	-	R	-	2				
150*	285	53	D	3	V	-	X	E	-	-	-	S	-	2				
200*	365	116	D	1	V	-	X	E	-	-	-	T						
250*	450	165	D	1	V	-	X	E	-	-	-	U						
300*	525	219	D	1	V	-	X	E	-	-	-	V						
350*	600	315	D	1	-	-	X	E	-	-	-	W						
400*	680	435	D	1	-	-	X	E	-	-	-	X						
450*	680	525	D	1	-	-	X	E	-	-	-	Y						
500*	830	590	D	1	-	-	X	E	-	-	-	Z						
600*	830	720	D	1	-	-	X	E	-	-	-	B						

SPACERS



LINING

- ▶ VIRGIN PTFE : DN 15 - DN 600
- ▶ ANTISTATIC PTFE, C4 = A : DN 15 - DN 400

DN	ØA	F (mm)	G (mm)		H (mm)		REFERENCE															
			L min.	L max.	L min.	L max.	1	2	3	4	5	6	7	8	9	10	11	12	13	14	15	16
15	51	10/15/20	15	60	60	100	D	3	V	-	•	-	x	x	x	H						
20	60	10/15/20	15	60	60	100	D	3	V	-	•	-	x	x	x	J						
25	70	10/15/20	15	60	60	100	D	3	V	-	•	-	x	x	x	K						
32	82	10/15/20	15	60	60	100	D	3	V	-	•	-	x	x	x	L						
40	92	10/15/20	15	60	60	100	D	3	V	-	•	-	x	x	x	M						
50	107	10/15/20	15	60	60	100	D	3	V	-	•	-	x	x	x	N						
65	127	10/15/20	15	60	60	100	D	3	V	-	•	-	x	x	x	O						
80	142	10/15/20	15	70	70	125	D	3	V	-	•	-	x	x	x	P						
100	162	10/15/20	15	70	70	125	D	3	V	-	•	-	x	x	x	Q						
125	192	10/15/20	15	70	70	150	D	3	V	-	•	-	x	x	x	R						
150	218	10/15/20	20	80	80	150	D	3	V	-	•	-	x	x	x	S						
200	273	10/15/20	20	80	80	200	D	1	V	-	•	-	x	x	x	T						
250	328	10/15/20	20	90	90	200	D	1	V	-	•	-	x	x	x	U						
300	378	10/15/20	20	90	90	200	D	1	V	-	•	-	x	x	x	V						
350	438	10/15/20	25	90	90	250	D	1	-	-	•	-	x	x	x	W						
400	488	10/15/20	25	90	90	250	D	1	-	-	•	-	x	x	x	X						
450	539	10/15/20	25	100	100	250	D	1	-	-	•	-	x	x	x	Y						
500	594	10/15/20	25	100	100	250	D	1	-	-	•	-	x	x	x	Z						
600	695	10/15/20	25	100	100	250	D	1	-	-	•	-	x	x	x	B						

• = F : Spacers shape F • = G : Spacers shape G • = E : Spacers shape H xxxx : length in mm

Massive PTFE spacer

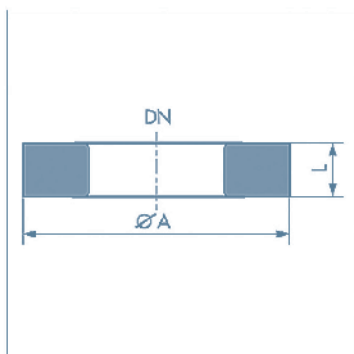

Shape F

Steel lined spacer

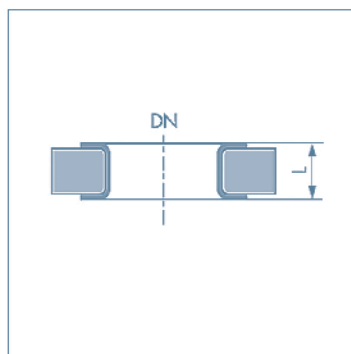

Shape G

Tube lined spacer

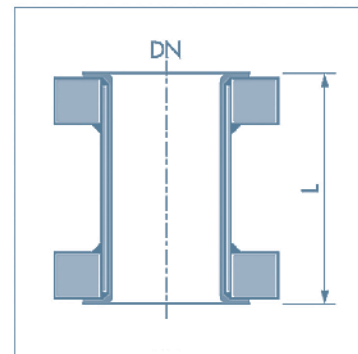

Shape H

Mersen also supplies inclined spacers type F

SPECTACLE BLINDS

LINING

- ▶ VIRGIN PFA : DN 20 - DN 200
- ▶ VIRGIN PTFE : DN 250 - DN 600
- ▶ ANTISTATIC PFA, C4 = A : DN 20 - DN 200
- ▶ ANTISTATIC PTFE, C4 = A : DN 250 - DN 400

DN	ØD	C	E	ØA	b	Weight	REFERENCE															
							1	2	3	4	5	6	7	8	9	10	11	12	13	14	15	16
20	61	75	35	16	14	1.9	D	3	V	-	O	B	-	-	-	J						
25	71	85	40	16	14	2.6	D	3	V	-	O	B	-	-	-	K						
32	82	100	50	19	14	3.9	D	3	V	-	O	B	-	-	-	L						
40	92	110	55	19	14	4.4	D	3	V	-	O	B	-	-	-	M						
50	107	125	65	19	14	5.9	D	3	V	-	O	B	-	-	-	N						
65	127	145	70	19	14	7.4	D	3	V	-	O	B	-	-	-	O						
80	142	160	40	19	14	8.5	D	3	V	-	O	B	-	-	-	P						
100	162	180	50	19	18	9.8	D	3	V	-	O	B	-	-	-	Q						
125	192	210	60	19	18	14	D	3	V	-	O	B	-	-	-	R						
150	218	240	65	24	18	19	D	3	V	-	O	B	-	-	-	S						
200	273	295	80	24	21	28	D	1	V	-	O	B	-	-	-	T						
250	328	350	65	24	23	39	D	1	V	-	O	B	-	-	-	U						
300	378	400	80	24	26	48	D	1	V	-	O	B	-	-	-	V						
350	438	460	65	24	28	64	D	1	-	-	O	B	-	-	-	W						
400	488	515	70	28	30	79	D	1	-	-	O	B	-	-	-	X						
450	538	565	60	28	30	94	D	1	-	-	O	B	-	-	-	Y						
500	593	620	70	28	33	123	D	1	-	-	O	B	-	-	-	Z						
600	695	725	80	32	38	191	D	1	-	-	O	B	-	-	-	B						

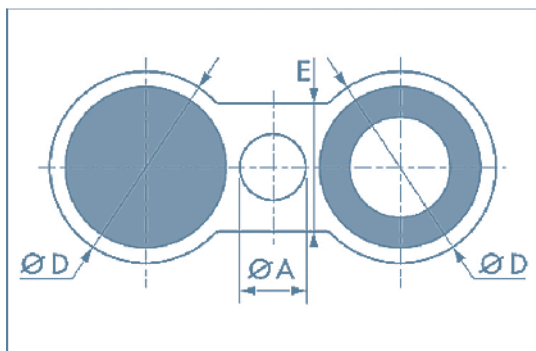

Spectacle blind (front view)

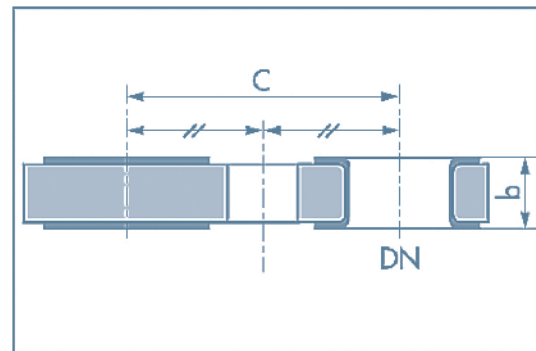

Spectacle blind (sectional view)

BLIND FLANGES & LATERAL TEES

BLIND FLANGES



LINING

- ▶ **VIRGIN PTFE :**
DN 15 - DN 600
- ▶ **PTFE ANTISTATIC, C4 = A :** DN 15 - DN 400

Possible to deliver with PTFE up to external diameter

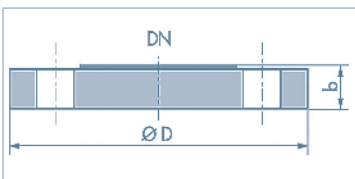

DN	ØD	b	Weight	REFERENCE															
	mm	mm		1	2	3	4	5	6	7	8	9	10	11	12	13	14	15	16
15	95	18	0.7	D	3	V	-	B	P	-	-	-	H						
20	105	20	1.0	D	3	V	-	B	P	-	-	-	J						
25	115	20	1.2	D	3	V	-	B	P	-	-	-	K						
32	140	20	1.3	D	3	V	-	B	P	-	-	-	L						
40	150	20	2.1	D	3	V	-	B	P	-	-	-	M						
50	165	22	2.9	D	3	V	-	B	P	-	-	-	N						
65	185	22	3.7	D	3	V	-	B	P	-	-	-	O						
80	200	24	4.9	D	3	V	-	B	P	-	-	-	P						
100	220	24	5.8	D	3	V	-	B	P	-	-	-	Q						
125	250	26	8.6	D	3	V	-	B	P	-	-	-	R						
150	285	26	10	D	3	V	-	B	P	-	-	-	S						
200	340	28	16	D	1	V	-	B	P	-	-	-	T						
250	395	30	24	D	1	V	-	B	P	-	-	-	U						
300	445	30	31	D	1	V	-	B	P	-	-	-	V						
350	505	30	41	D	1	-	-	B	P	-	-	-	W						
400	565	30	50	D	1	-	-	B	P	-	-	-	X						
450	615	30	65	D	1	-	-	B	P	-	-	-	Y						
500	670	31	76	D	1	-	-	B	P	-	-	-	Z						
600	780	36	132	D	1	-	-	B	P	-	-	-	B						

LATERAL TEES

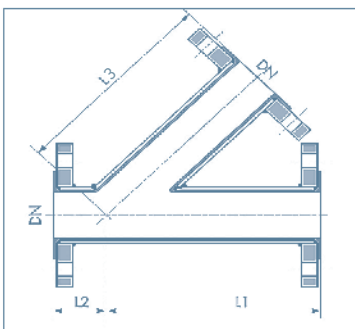

Lateral tees



DN	L1	L2	L3	Weight	REFERENCE															
	mm	mm	mm		1	2	3	4	5	6	7	8	9	10	11	12	13	14	15	16
25	60	160	160	5,2	D	3	V	-	T	L	-	-	-	K						
32	60	200	200	6,5	D	3	V	-	T	L	-	-	-	L						
40	90	210	200	8,1	D	3	V	-	T	L	-	-	-	M						
50	50	190	230	11,4	D	3	V	-	T	L	-	-	-	N						
65	70	280	280	17	D	3	V	-	T	L	-	-	-	O						
80	60	270	270	24	D	3	V	-	T	L	-	-	-	P						
100	115	295	295	44	D	3	V	-	T	L	-	-	-	Q						

LINING

- ▶ **VIRGIN PFA :** DN 25-100
- ▶ **ANTISTATIC PFA, C4 = A :** DN 25 - DN 100

For reducing lateral please contact us



GLOBAL EXPERT IN ELECTRICAL
POWER AND ADVANCED MATERIALS

EUROPE, MIDDLE EAST & AFRICA

FRANCE
info.pagny@mersen.com

GERMANY
Tantalum: info.lsg@mersen.com
Graphite/SiC/Process techno: info@gab-neumann.de

ITALIA
ace.italia@mersen.com

MIDDLE EAST & AFRICA
info.pagny@mersen.com

RUSSIA & EASTERN EUROPE
info.pagny@mersen.com

SOUTH AFRICA
SA.marketing@mersen.com

SPAIN
contact.iberica@mersen.com

THE NETHERLANDS
contact.schiedam@mersen.com

TURKEY
sales.istanbul@mersen.com

UNITED KINGDOM
ace.uk@mersen.com

ASIA

CHINA
info.xianda@mersen.com

INDIA
sales.ace.india@mersen.com

JAPAN
ace.japan@mersen.com

KOREA
sales.korea@mersen.com

SOUTH EAST ASIA
graphite.sales@framet.com

NORTH AMERICA / CANADA

USA Salem VA
sales.salem@mersen.com

USA Gonzales LA
Graphiterepairs.gonzales@mersen.com

USA Louisville KY
Sales.lgi@mersen.com

SOUTH AMERICA

ARGENTINA
infos.latam@mersen.com

BRAZIL
vendas.ace.brasil@mersen.com

CHILE
ventas.chile@mersen.com

COLOMBIA
ace.latam@mersen.com

MEXICO & LATIN AMERICA
ace.latam@mersen.com

